

## TECHNICAL SPECIFICATION

### INPUT SPECIFICATION:

Sr.	INPUT		Range
1	TC-J	J	0 To 700 °C
2	TC-K	K	0 To 1300 °C
3	TC-T	T	0 To 350 °C
4	TC-R	R	0 To 1650°C
5	TC-S	S	0 To 1650°C
6	TC-E	E	0 To 650°C
7	TC-N	N	0 To 1250°C
8	PT	PT	-100 To 400°C
9	PT-1	PT.1	-100.0 To 400.0°C
10	0-10VDC	0-10	-1999 To 9999
11	0-5VDC	0-5U	-1999 To 9999
12	4-20mA	4-20	-1999 To 9999
13	0-20mA	0-20	-1999 To 9999

<b>Indication Accuracy</b>	±1% of FSD ± 1°C (FSD: full scale deflection)
<b>Resolution</b>	J,K,T,R,S,E,N,PT-100 = 1°C
	PT.1 = 0.1°C
	0-10V DC,0-5VDC,0-20mA DC,4-20mA DC = 0.1,0.01,0.001,0001

### OUTPUT SPECIFICATION:

#### 1) Relay Output/ SSR Output (Factory Set)

Relay/SSR	2
Relay Type	(NO-C)
Rating	Relay:10A, 230VAC/30V DC SSR: 12VDC,30mA

#### 2) 24VDC Transmitter supply

### AUXILIARY SUPPLY:

Supply voltage	100 to 250V AC, 50-60Hz
Power consumption (VA RATING)	Approx. 7 VA @ 230V AC MAX

### ENVIRONMENT CONDITION:

Operating Temp.	0°C to 55°C
Relative Humidity	UP to 95% RH (non-condensing)
Protection Level	IP-65 (Front side) As per IS/IEC 60529 : 2001

### DIMENSION & DISPLAY:

Size	48(H) X 48(W) X 70(D)/ Cutout 44(H) X 44(W)
Display	Upper: 4 digit, 7 segment, 0.70" White Lower: 4 digit, 7 segment, 0.50" Green

### COMMUNICATION:

Protocol	Modbus RTU Serial
Standard	RS - 485
Communication method	2 wire half duplex
Communication rate	9600,19200
Address range	1-127
Data type	Integer

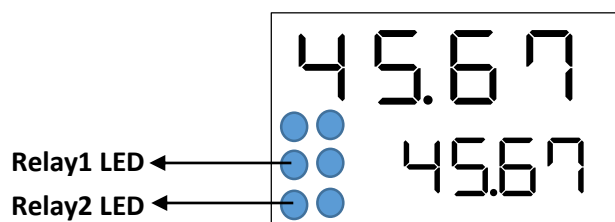
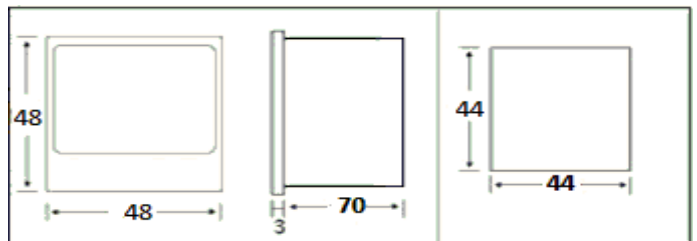

### Key Operations:

- Press SET Key to enter in programming mode.
- Press SET Key to go to next parameter.
- Use Up Or Down key to change value of parameter.
- Press ENT Key to save change in setting
- To start Auto-Tuning Press Up key for 6 sec. (In PID Mode).

## Set point Setting:

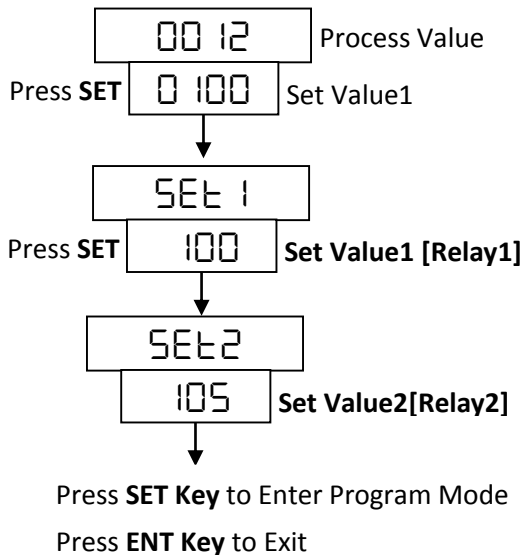

## Basic Configuration

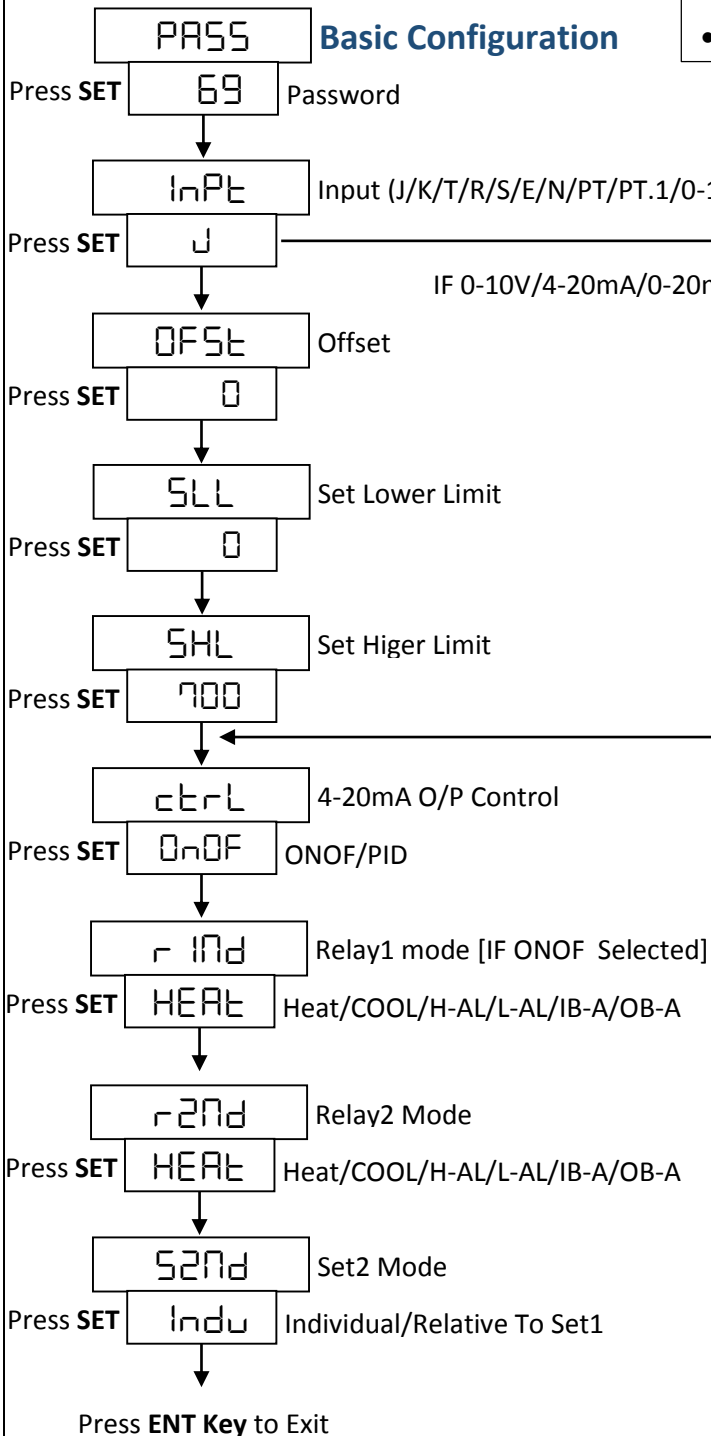

## PID Auto-Tuning

- The Auto-tuning function automatically computes and sets the proportional band (P), integral time (I), Derivative time (D), cycle time as per process characteristics.
- While Auto-tune is in progress, lower display alternate shows AT & set-point. Lower display stops alternating between AT & set-point at the completion of Auto-tuning.
- Press **UP (↑)** Key 6 sec. to start tuning .

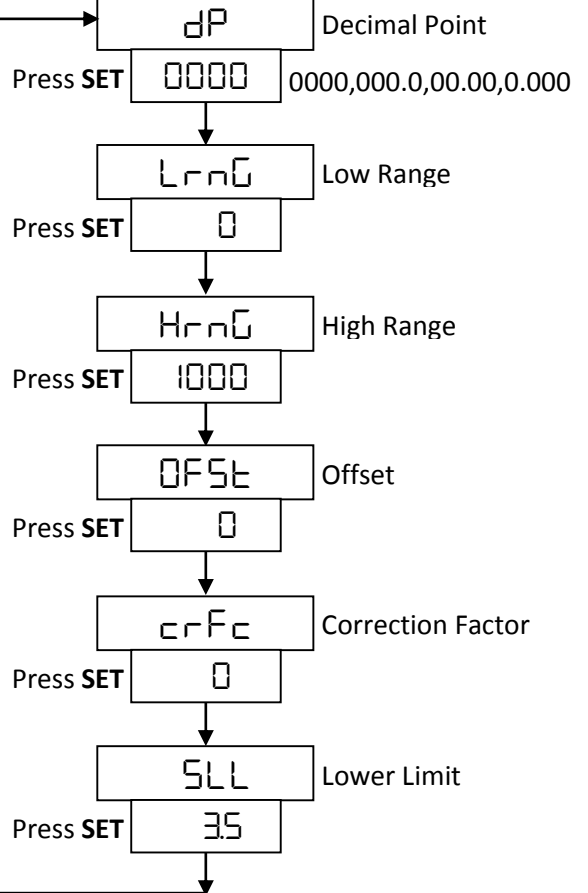

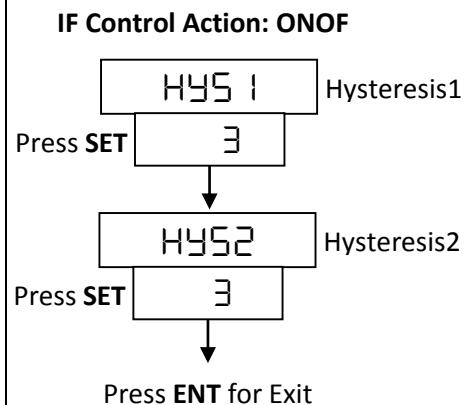
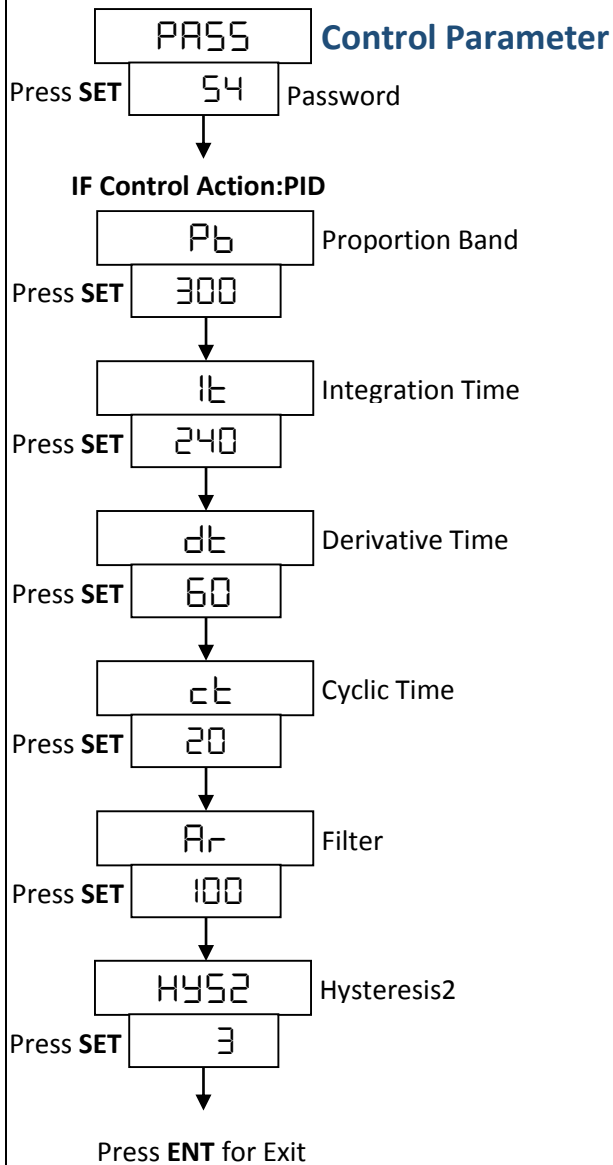

## Relay1 & Relay2 Operating Modes

- Heat Mode:**

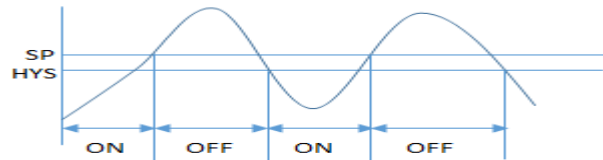

Initially Relay will be on condition. When Process value equals to Set Point Relay will turn off. When Process value equal to Set Point-Hysteresis then again Relay will be on.

- Cool Mode:**

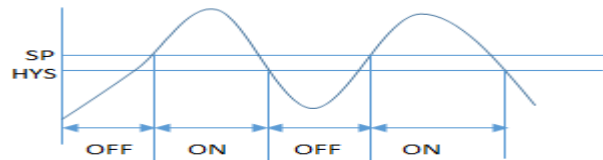

Initially Relay will be off condition. When Process value equals to Set Point Relay will turn on. When Process value equal to Set Point-Hysteresis then again Relay will turn off.

- High Alarm Mode [H-AL]:**

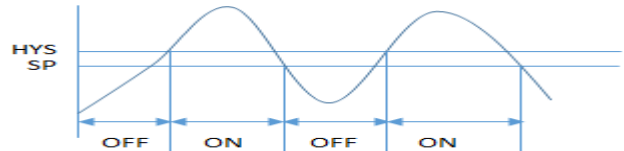

Initially Relay will be off condition. When Process value equals to Set Point + Hysteresis Relay will turn on. When Process value equal to Set Point then again Relay will turn off.

- Low Alarm Mode [L-AL]:**

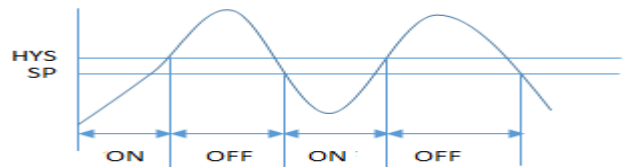

Initially Relay will be on condition. When Process value equals to Set Point + Hysteresis Relay will turn off. When Process value equal to Set Point then again Relay will turn on.

- In Band Alarm Mode [IB-A]:**

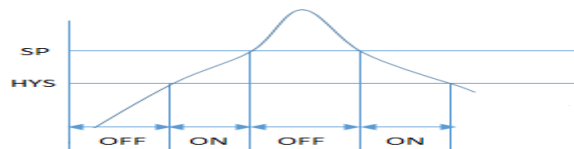

Relay will be on between Set point & Hysteresis condition. If Set Point=100 & Hysteresis=3 than Relay on between 97to100

- Out Band Alarm Mode [OB-A]:**

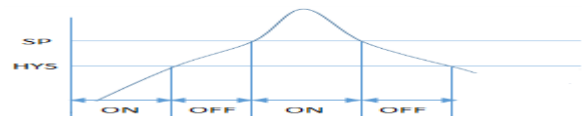

Relay will be off between Set point & Hysteresis condition. If Set Point=100 & Hysteresis=3 than Relay off between 97to100.

## Modbus Parameter

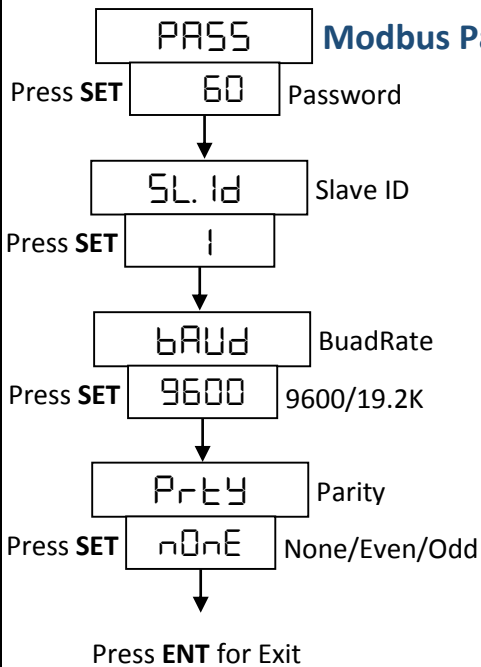

Data type = Sign Integer show value as per following		
Input	Actual Value	DP Selection
J/K/T/R/S/E/N/PT	Value/1	Fix
PT.1	Value/10	Fix
0-10VDC	Value/1	0
4-20mA DC	Value/10	1
0-5VDC	Value/100	2
0-20mA DC	Value/1000	3

Read/Write	Parameter	Read Function Register(0x03/0x04) ADDRESS(INT)	Write Function Register (0x06/0x10) ADDRESS(INT)
R	Process Value	40001/30001	-
R/W	Set Value1	40002/30002	40002
R/W	Set Value2	40003/30003	40003
R/W	Input*	40004/30004	40004
R/W	Lower Range(0-10V,4-20mA)	40005/30005	40005
R/W	Higher Range(0-10V,4-20mA)	40006/30006	40006
R/W	OFFSET	40007/30007	40007
R/W	CRFC(0-10V,4-20mA)	40008/30008	40008
R/W	SSL	40009/30009	40009
R/W	SHL	40010/30010	40010
R/W	Control Action*	40011/30011	40011
R/W	Relay1 Mode*	40012/30012	40012
R/W	Relay2 Mode*	40013/30013	40013
R/W	Hysteresis1	40014/30014	40014
R/W	Hysteresis2	40015/30015	40015

\*INPUT (Range: 0-12) 0:TC-J, 1:TC-K, 2:TC-T, 3:TC-R, 4:TC-S, 5:TC-E, 6:TC-N, 7:PT, 8:PT.1, 9:0-10V, 10:0-5V, 11: 4-20mA, 12: 0-20mA

\*Control Action (Range: 0-2) 0: ONOF, 1: PID

\*Relay1/2 Mode (Range: 0-5) 0:HEAT, 1:COOL,2:H-AL,3:L-AL,4:IB-A,5:OB-A